

Lighting System

PARTS (Your parts may vary)

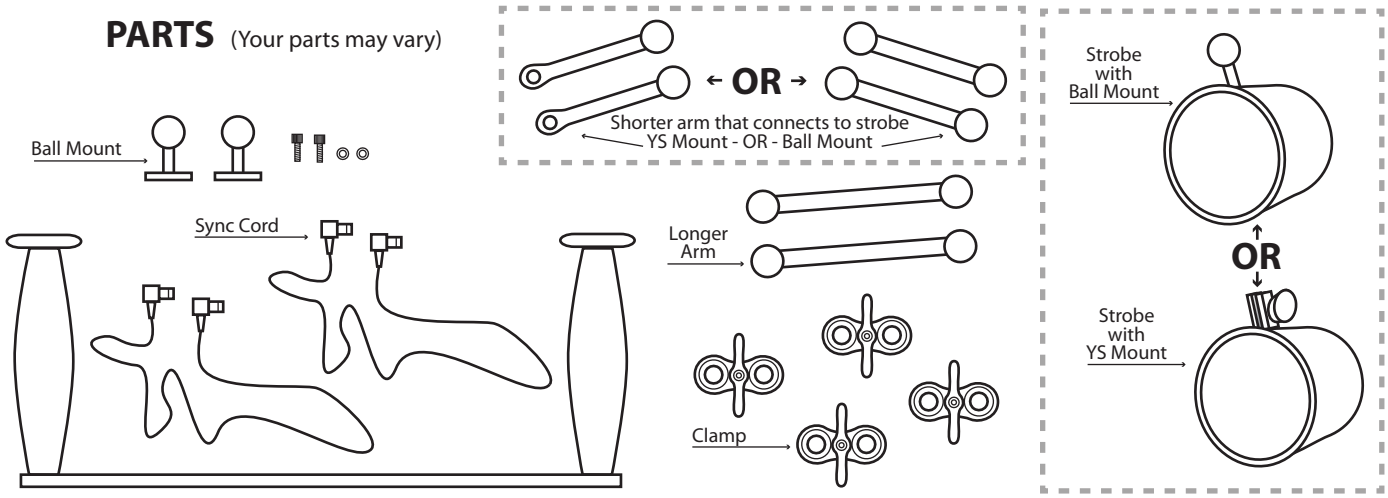

ASSEMBLY

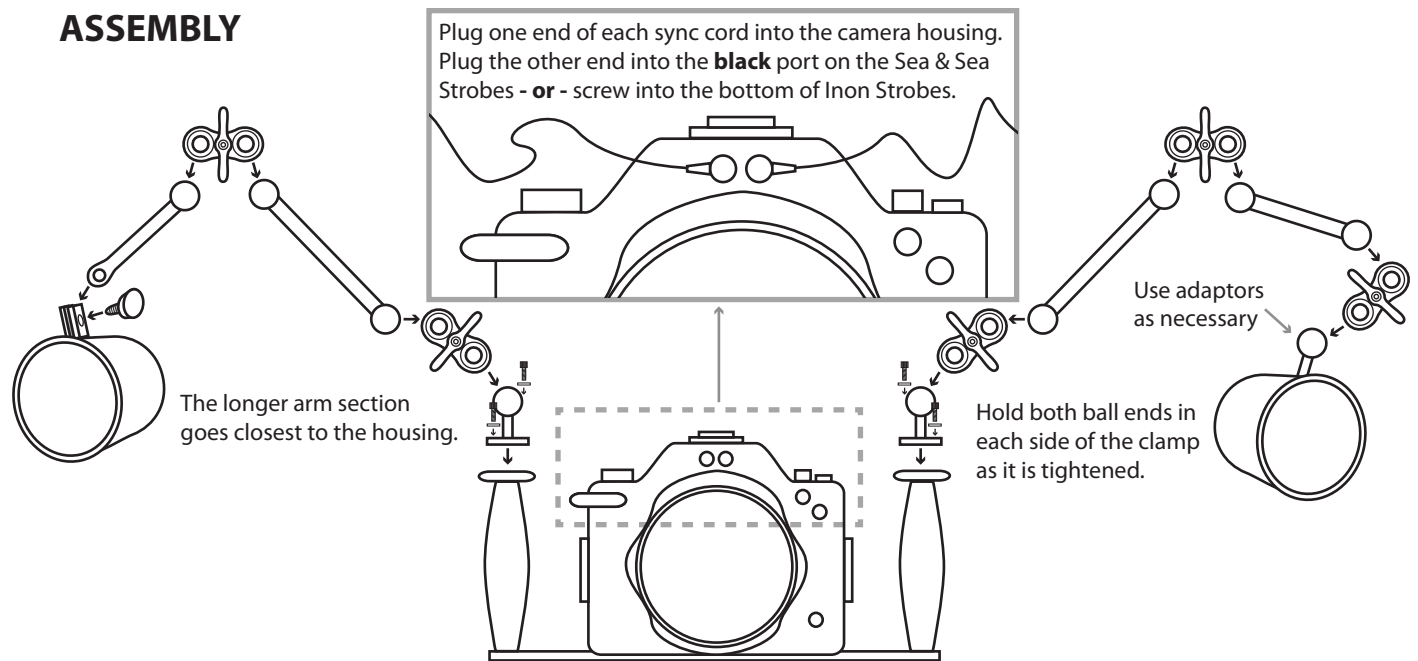

READY TO GO!

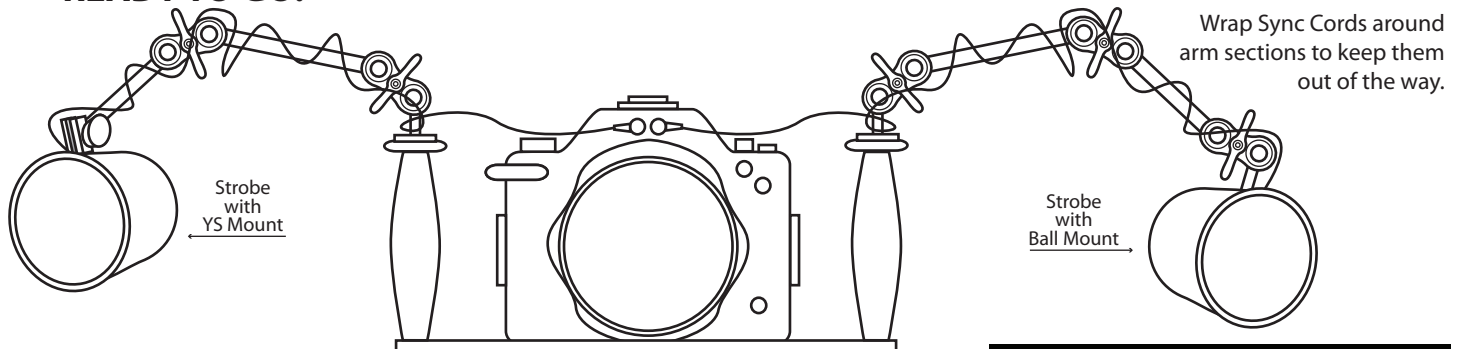

Arms and lights may be tucked in and tightened to get them out of the way and keep them safe during water entry.

See our "Strobe Positioning" handbook - available at:
<https://www.opticaloceansales.com/files/OOS-Strobe-Positioning.pdf>
 for more information.

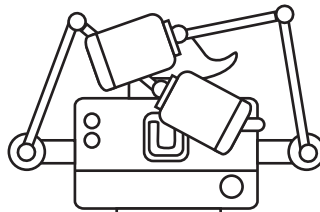

OPTICAL OCEAN SALES
 UNDERWATER PHOTOGRAPHY EQUIPMENT

1800 Westlake Ave N., Suite 201,
 Seattle, WA 98109 1-800-359-1295
 Website: www.opticaloceansales.com
 Email: orders@opticaloceansales.com